

RX16

16 CHANNEL WIRELESS RECEIVER

INSTALLATION AND OPERATING INSTRUCTIONS

FORWARD

The RX16 is a modular radio receiver with multi switched outputs built in an IP66 weather proof plastic enclosure. The unit comes fitted with one 4 zone module (PC4) as standard and a further three (PC4) 4 zone modules may be fitted to increase the capacity to a maximum of sixteen outputs. This product is primarily intended for use with speed dome cameras where it will receive data from wireless PIR detectors (TX500) around the area and give the appropriate output to position the camera. It can also be used with multi zone alarm panels for other security applications where remote PIR detectors are required. Each group of four outputs may be selected to be either N/O or N/C. Each individual output may be selected to be inhibited by a global inhibit function. (See Power & Inhibit Connector).

There is also a module with voltage free change over contacts (PC1). This module has an adjustable timer and light sensor.

CONNECTIONS TO THE MOTHER BOARD

AERIAL

The RX16 comes with a standard aerial which must be connected using the screw fixing at the top of the case. The BNC socket is NOT used in this instance.

For long range reception, special long range aerials are available. These aerials plug onto the BNC socket on the left hand side of the mother board. The standard aerial must NOT be used in conjunction with these aerials. The aerial cable should be passed through the left hand cable gland and the BNC plug fitted to it.

For best results, the aerial should be as high as possible and located where it is in line of sight with the PIR's. Any construction in the path will reduce the range.

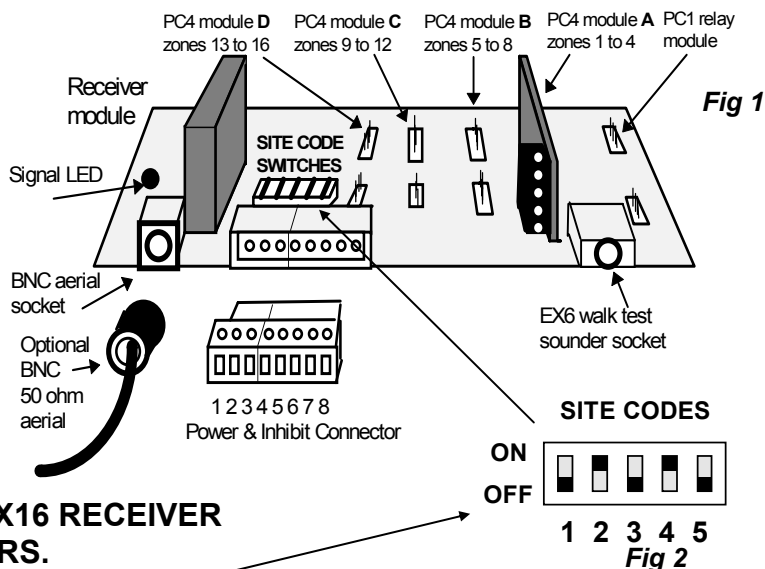

SETTING THE SITE CODES FOR THE RX16 RECEIVER AND TX500 WIRELESS P.I.R. DETECTORS.

SITE CODES

This is the SITE CODE switch on the RX16 receiver situated on the mother board as shown in Fig 1.

Site codes are the receivers own unique code rather like a key to a lock which matches the site code in the TX500 wireless P.I.R. detectors. All the detectors used with an RX16 receiver MUST have the same SITE codes. If other RX16 receivers are used then they should have a different SITE code otherwise both receivers will respond to the same P.I.R. detectors.

The RX16 site code must match the site code in the transmitter. See TX500 instructions.

Fig 2 shows a typical example of a SITE code.

1 OFF, 2 ON, 3 OFF, 4 ON & 5 OFF.

IMPORTANT. DO NOT USE ALL ON OR ALL OFF AS THESE ARE NOT VALID CODES AND THE RECEIVER MAY FALSE ACTIVATE.

PC4 MODULE SETTING & CONNECTIONS

The RX16 has one PC4 module fitted as standard for zones 1 to 4. In this position the zones are as follows. A = 1, B = 2, C = 3 & D = 4. Ground (GND) is common to the four outputs.

Use GND and A to go to the first alarm input of the apparatus to be controlled. GND and B to the second input and so on.

Three further PC4 modules may be plugged on in the positions marked on the mother board.

This would give the maximum 16 zones available.

The PC4 modules will automatically adjust to the correct zones according to the positions to which they are fitted. **The five position DIP switch sets the following features.**

Outputs normally open or normally closed
and zone inhibit.

The transistor outputs can be configured to be open collector (N/O) or closed collector (N/C) so that they may be coupled to most makes of speed dome camera, switcher, multiplexer or alarm panel. To change the output, select switch 5 on the DIP switch as shown in Fig 3. With switch 5 in the ON position the outputs will be N/O. In the OFF position the output will be N/C.

Switches 1, 2, 3 & 4 connect zones 1, 2, 3 & 4 to the inhibit circuit. **For example,** if you want to inhibit zone 4 at certain times of the day or night, put switch 4 on module A **ON**. To inhibit the zone close a switch between terminal 3 to terminal 7 on the Mother board.

To inhibit zone 8, put switch 4 on module B **ON**. To inhibit the zone close a switch between terminal 3 to terminal 6 on the Mother board. For further information see POWER & INHIBIT CONNECTOR.

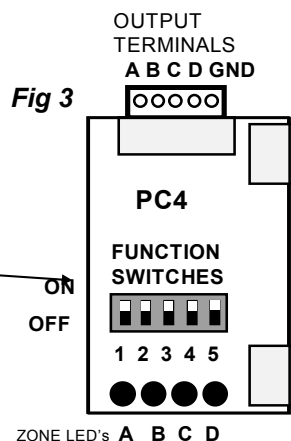

PC1 MODULE SETTINGS & CONNECTIONS

Fit the PC1 on the far right hand side of the mother board in accordance with the PC1 instructions and as shown in Fig 1. The PC1 has a relay with voltage free change over contacts which may be used to switch low voltage or mains voltage applications. Fig 5. The relay is rated at 16 amps and has a 4000 volt electrical isolation making it safe to switch mains voltage. The PC1 will activate from any one of the 16 unit codes. The timer adjuster is variable from 5 seconds to 5 minutes and the light sensor adjuster is variable to allow the module to either work 24 hours a day or only to work at night. Fig 4. In addition to the light sensor, the PC1 can also be inhibited just like the PC4 modules. To inhibit this module connect a switch to terminals 3 and 8 on the mother board. When the switch is closed the PC1 will not operate.

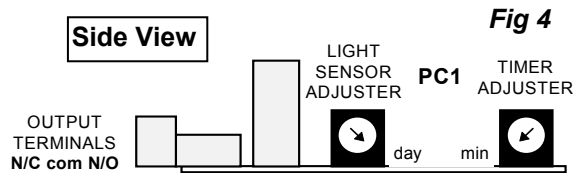

Fig 4

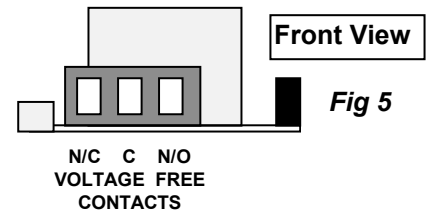

Fig 5

With the light sensor adjuster fully clockwise the PC1 will be able to operate 24 hours a day providing the transmitters are set to do the same. (TX500's also have built in light sensors and this must be taken into consideration). Turn the light sensor adjuster fully clockwise to inhibit operation during day light. The timer is adjustable from 5 seconds to 5 minutes. With the timer adjuster turned fully anti-clockwise the relay will operate for 5 seconds. The timer is re-activated after each detection and therefore the maximum time will be 5 minutes after the last detection.

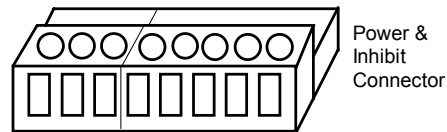
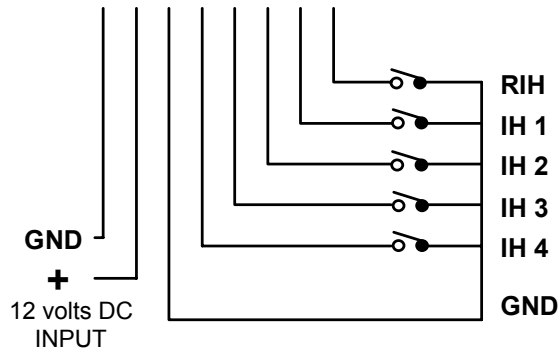

Fig 6

POWER & INHIBIT CONNECTOR

1. GND = 0 volts DC ——— 12 volt DC input
2. + = 12 volts DC ——— 12 volt DC input
3. GND = 0 volts DC common for inhibit switches
4. IH4 = inhibit zones 13 to 16 PC4
5. IH3 = inhibit zones 9 to 12 PC4
6. IH2 = inhibit zones 5 to 8 PC4
7. IH1 = inhibit zones 1 to 4 PC4
8. RIH = relay inhibit PC1



To the right of the aerial socket is a plugable 10 way screw terminal connector. Fig 6.

POWER: Connect a 12 volt DC regulated 500 m/a power supply to terminals 1 and 2 as shown in Fig 6.

INHIBIT: Terminals 3,4,5,6,7 and 8 are for zone and relay inhibiting. You may select any of the zones to be controlled by an "inhibit" switch or switches. (See PC4 section). The PC1 relay module may also be controlled by an "inhibit" switch.

WALK TEST

Each TX500 PIR detector has a socket into which a EX6 sounder can be plugged which will sound each time movement is detected. This sounder (EX6) can also be plugged into the RX16's Walk Test Sounder Socket and will sound each time any of the PIR detectors signal to the RX16. With this facility you can walk round a large building and be able to hear the sounder on the RX16 each time you pass a detector. If the sounder fails to operate and you know the detector to be OK having previously tested it with a sounder then this would indicate a transmission problem which could be overcome with better aerials or increased transmitter output. It may also be that the wrong SITE code has been used and does not match the RX16's.

UNIT CODES.

Unit codes are the transmitters individual identifying code and activate the related zone on the RX16 receiver. Switches 6, 7, 8 & 9 on the TX500 set the unit codes. Fig 7. The following table gives the unit code equivalent for the zones.

6	7	8	9	ZONE
ON	ON	ON	ON	1
OFF	ON	ON	ON	2
ON	OFF	ON	ON	3
OFF	OFF	ON	ON	4
ON	ON	OFF	ON	5
OFF	ON	OFF	ON	6
ON	OFF	OFF	ON	7
OFF	OFF	OFF	ON	8
ON	ON	ON	OFF	9
OFF	ON	ON	OFF	10
ON	OFF	ON	OFF	11
OFF	OFF	ON	OFF	12
ON	ON	OFF	OFF	13
OFF	ON	OFF	OFF	14
ON	OFF	OFF	OFF	15
OFF	OFF	OFF	OFF	16

Fig 7

Inside the TX500 Wireless P.I.R. detector showing the SITE and UNIT code switches.

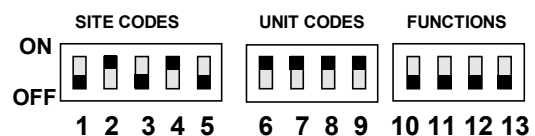

N.B. The site code is the same as the site code on the RX16 as shown in Fig 2. This UNIT CODE is Zone 1 as shown in the table.

QUICK START INSTRUCTIONS.

Step 1.

Fix the RX16 to a wall using the screw holes on each corner of the plastic case.

Step 2.

Screw the wire aerial onto to the top of the case using the screw provided. The BNC socket on the mother board is not used with this aerial.

If a different aerial is to be used then do not fit the aerial provided. The BNC socket is used for special aerials.

Step 3.

Connect a 12 volt DC 500mA supply to terminals 1&2 on the Power & Inhibit connector as shown in Fig 1.

Step 4.

Make a code combination with the RX16 SITE CODE switches like the one in Fig 2.

Step 5.

Set the same code on all the TX500 detectors that are to be used with the RX16. Fig 3.

Step 6.

If an EX11 is available, plug it into the Walk Test Sounder Socket.

Step 7.

Decide on the appropriate unit code and set it on the TX500. The example in Fig 3 shows unit code 1. Connect a PP3 battery to the TX500 and try a test transmission by operating switch 10. The sounder (EX11) will sound momentarily and the SIGNAL LED on the Mother board will light. The ZONE LED on the appropriate PC4 module will light and remain illuminated until a different UNIT code is received. In this example zone 1 will light and the output A will open circuit for one second.

If more that four zones are required, plug further PC4 modules on to the RX16 as shown in Fig 1. The power should be switched OFF during this procedure.

Step 8.

Test each zone and TX500 as described to ensure that the correct codes have been set.

If you want to check the outputs, connect a volt meter between terminal 2 (+) on the Power & Inhibit Connector and any one of the outputs on the PC4 module A,B,C or D. The meter will either show 12 volts that disappears for one second or 0 volts that goes to 12 volts for one second according to the position of switch 5 on the PC4.

Putting your meter between GND and an output will NOT show any reading.

Step 9.

The PC4 outputs wire to the Alarm inputs of the apparatus to be controlled as follows:

PC4 position 1.	PC4 position 2.	PC4 position 3.	PC4 position 4.
GND and A for zone 1	GND and A for zone 5	GND and A for zone 9	GND and A for zone 13
GND and B for zone 2	GND and B for zone 6	GND and B for zone 10	GND and B for zone 14
GND and C for zone 3	GND and C for zone 7	GND and C for zone 11	GND and C for zone 15
GND and D for zone 4	GND and D for zone 8	GND and D for zone 12	GND and D for zone 16

For further technical help and advice please contact:

Luminite Electronics Ltd 2a Bellevue Road, Friern Barnet, LONDON N11 3ER.
Tel: 020 8361 5255 Fax: 020 8368 3952 <http://www.luminite.co.uk> tech@luminite.co.uk