



Masthead

Relay

Unit 4X4

Handbook

Type: LGMRU4x4 v4.74

Issue 5.

PRE-INSTALLATION NOTES

Unpacking.

On receipt, inspect the package and contents for signs of damage. If damage has occurred, advise the carrier and/or suppliers immediately. Inspect the contents to confirm that all items are present and undamaged. If any items are missing or damaged, contact the supplier immediately. It is advisable that the original carton is retained as this forms the safest transport container in the event that a unit has to be returned for any reason.

Servicing.

This unit should not require general servicing. Any repair work should only be undertaken by Luminite Electronics Ltd.

Moisture.

Do not expose the internal electronics of this unit to moisture i.e. take care during installation not to allow rain or damp into the product. When the product is sealed it is water resistant to IP66.

Box Contents.

1 x GENESIS Masthead Relay Unit LGMRU4x4
1 x 1/4 wave antenna

Copyright 2005 Luminite Electronics Ltd

All rights reserved. Unauthorised duplication of this handbook by any means mechanical or electrical, is strictly prohibited without the express written permission of Luminite Electronics Ltd.

Luminite Electronics Ltd acknowledge all registered trademarks

Luminite Electronics Ltd reserve the right to make changes to this handbook and to its products without prior notice in order to improve design or performance characteristics.

INDEX page

Introduction and positioning the Masthead/Repeater.	2
Unit groups	3
Mode switches and connections.	4
Code and function switches.	5
Site codes.	6
Repeater mode & special functions.	7
Walk Test & Repeater principals.	8
Sub Nets examples.	9
Setting up & testing the LGMRU4X4.	10 & 11
Engineers notes	12
Types of receivers.	13

Introduction.

The Masthead Relay Unit provides a simple interface for virtually any kind of alarm input. Because it is weather proof to IP66 it can be fitted with a dome camera and connected directly into the alarm pre-sets.

This unit provides either 4 alarm outputs with corresponding tamper outputs or eight alarm outputs without tampers. DIL switches set the different modes as well as the unit code groups.

Expansion cards are available to increase the number of alarm outputs.

There is no limit to the number of LGMRU4x4 units that can be used on any one system.

The LGMRU4x4 will also re-transmit any incoming data which can then be received by a Walk Test Indicator

Masthead Relay
Unit 4x4 or 8

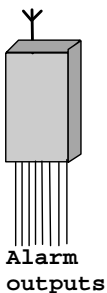
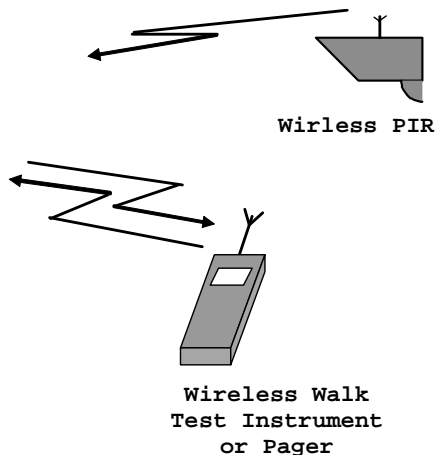

Fig 1.



Antenna connection.

Connect the supplied 1/4 wave antenna onto the BNC socket and pass through the left hand gland.

For even better results, use an external antenna (AE434). Follow the same procedure but instead pass the coaxial cable through the cable gland and crimp on the 50ohm BNC plug supplied with the AE434.

Positioning the LGMRU4x4.

The Receiver is weather resistant to IP66 and may be mounted on the outside of a building or on a mast with a camera.

DO NOT drill extra holes in the product. The cable glands MUST face downwards.

For best radio reception mount the unit high up at about the first or second floor level.

Do not mount it too high as this has the same effect as mounting it too low and will shorten the range.

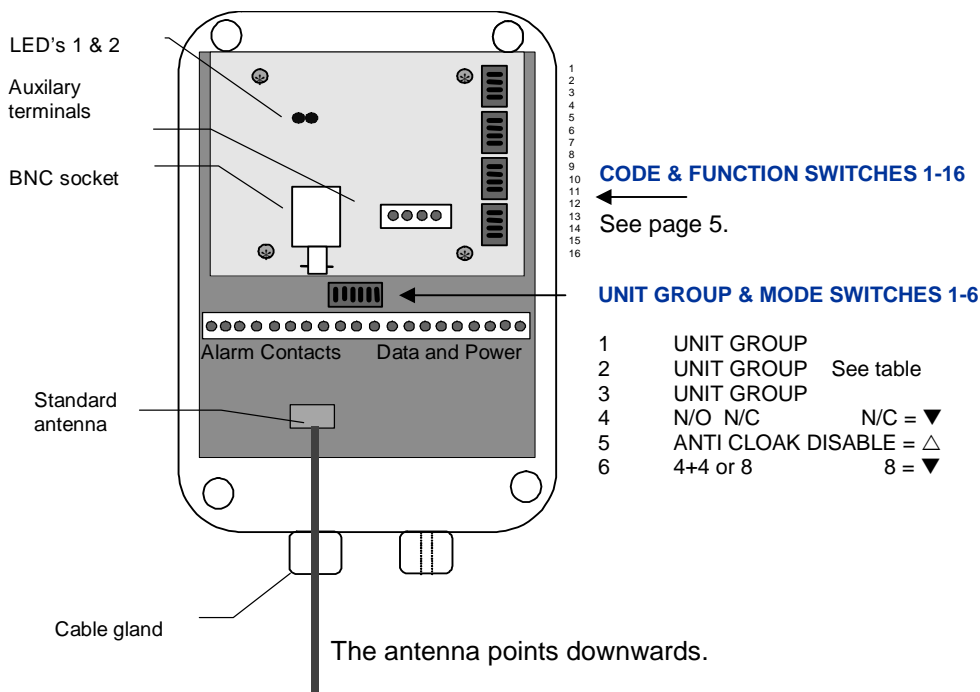

UNIT GROUPS with switches 1-3. Switch 6 sets 4x4 or 8 alarms. When set to 4 alarms there are also 4 corresponding tampers.

SWITCHES	1	2	3	6 △	6 ▼
UNIT GROUPS	△	△	△	1-4	or 1-8
	△	△	▼	5-8	or 9-16
	△	▼	△	9-12	or 17-24
	△	▼	▼	13-16	or 25-32
	▼	△	△	17-20	or 33-40
	▼	△	▼	21-24	or 41-48
	▼	▼	△	25-28	or 49-56
	▼	▼	▼	29-32	or 57-64

MODE SWITCHES

4

- △ N/O Alarm contacts only
- ▼ N/C Alarm contacts only

5

- △ Anti-cloak tamper disabled
- ▼ Anti-cloak tamper enabled

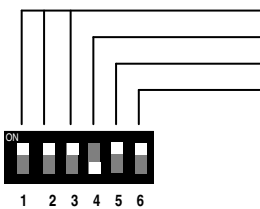

TYPICAL EXAMPLE 1

Alarms 1-4 & Tamper 1-4.
N/C alarm contacts. (Tampers always N/C)
Anti-cloak tamper Disabled
4x4 mode

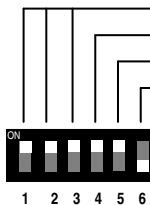

TYPICAL EXAMPLE 2

Alarms 1-8. No tampers
N/O contacts
Anti-cloak Tamper Disabled
8 way mode

CONNECTIONS

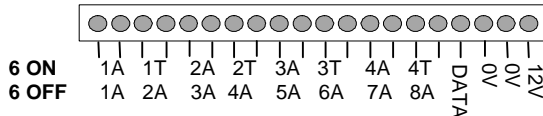

Power supply.

Connect 12 volts DC @ 200mA to the power input terminals on the far right hand side of the lower circuit board.

Do not connect to the upper circuit board terminals.

Data output.

These terminals can connect in parallel to further relay boards (LGREM4X4) to expand the alarm output capability. See LGREM4X4 installation instructions.

Connecting to alarm system.

MOS relay outputs can be set as either Normally Open (N/O) or Normally Closed (N/C) by changing switch number 4 on the Unit Group & Mode Switches.

These contacts are volt free but are for switching signal levels only. (Max 100mA).

A is an alarm pair output and **T** is a tamper pair output which is associated with the alarm pair directly to its left.

By changing switch **6** on the Unit Group & Mode Switches the unit provides eight outputs but without tampers.

CODE AND FUNCTION SWITCHES.

There are sixteen switches which have the following functions.

- SWITCHES 1-5 Site Codes
- SWITCHES 6-8 Sub Net Code A
- SWITCHES 9-11 Sub Net Code B
- SWITCHES 12-16 Special functions



SITE codes separates one site from another. There are 32 site codes to choose from and it is recommended that each new installation should be set to a different site code. The site code can also be used to identify the installation. EG: (14) EZ Car Rentals. All the detectors on the system must have the same site code. The masthead and any repeaters must also have the same site code. If a pager is to be used, then that must also have the same site code.

When initially installing the system or when carrying out a maintenance check, type the site code number into the Walk Test Indicator.

SUB NET codes divide the site up into sections and are only needed if one or more repeaters are used. If there are no repeaters, leave the sub net codes at 1. All PIR's and repeaters on the site are set to the same SITE code but will only communicate with a masthead or repeater which has the same sub net code. Distant PIR's will need to route through one or more repeaters. Those PIR's must send the sub net code that has been set on the nearest repeater. That repeater then sends the sub net code of the next repeater or masthead if it is next in line.

The Masthead has two Sub Net Code settings. A & B. As a Masthead, only the RECEIVE switches (**A**) are applicable. If the unit is configured as a repeater, then the SEND switches (**B**) also apply.

Pagers and Walk Test Instruments do not have Sub Net Codes and will respond to the Masthead and any repeaters as long as they are the same Site Code. (See separate Walk Test & Pager Instructions). Up to seven repeaters and one masthead may be deployed.

EXAMPLE

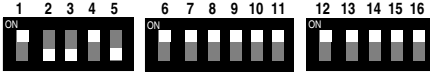

In this example Sit Code 14 has been set. The Sub Net Codes are set to the default setting of 1.

	SWITCHES	1	2	3	4	5
SITE CODES						
1		△	△	△	△	△
2		△	△	△	△	▼
3		△	△	△	▼	△
4		△	△	△	▼	▼
5		△	△	▼	△	△
6		△	△	▼	△	▼
7		△	△	▼	▼	△
8		△	△	▼	▼	▼
9		△	▼	△	△	△
10		△	▼	△	△	▼
11		△	▼	△	▼	△
12		△	▼	△	▼	▼
13		△	▼	▼	△	△
14		△	▼	▼	△	▼
15		△	▼	▼	▼	△
16		△	▼	▼	▼	▼
17		▼	△	△	△	△
18		▼	△	△	△	▼
19		▼	△	△	▼	△
20		▼	△	△	▼	▼
21		▼	△	▼	△	△
22		▼	△	▼	△	▼
23		▼	△	▼	▼	△
24		▼	△	▼	▼	▼
25		▼	▼	△	△	△
26		▼	▼	△	△	▼
27		▼	▼	△	▼	△
28		▼	▼	△	▼	▼
29		▼	▼	▼	△	△
30		▼	▼	▼	△	▼
31		▼	▼	▼	▼	△
32		▼	▼	▼	▼	▼

REPEATER MODE.

With switch **13** down the Masthead becomes a REPEATER. In this mode the unit will receive PIR detectors and relay them on to a distant masthead transceiver.

Up to eight repeaters can be used in a chain for very long range reception. Each repeater will need to have a different Sub Net Code setting.

SUB NET CODE SWITCHES

		SWITCHES	6	7	8
SUB NET CODES		1	△	△	△
		2	△	△	▼
RECEIVING A		3	△	▼	△
		4	△	▼	▼
		5	▼	△	△
		6	▼	△	▼
		7	▼	▼	△
		8	▼	▼	▼

Sub Net A must be the same as the PIR detectors Sub Net code that are intended to communicate with this repeater.

		SWITCHES	9	10	11
SUB NET CODES		1	△	△	△
		2	△	△	▼
TRANSMITTING B		3	△	▼	△
		4	△	▼	▼
		5	▼	△	△
		6	▼	△	▼
		7	▼	▼	△
		8	▼	▼	▼

SPECIAL FUNCTION SWITCHES.

Switches 12 through to 16 have the following functions.

FUNCTION	SWITCHES	12	13	14	15	16
Reserved		△	△	△	△	▼
Relay 8 light sensor		△	△	△	▼	△
Relay 1 global output		△	△	▼	△	△
Repeater		△	▼	△	△	△
Walk Test		▼	△	△	△	△

The Walk Test Instrument does not take any notice of Sub Net codes and will receive from anywhere on the site either directly from the Masthead or via Repeaters. All these products will be set to the same Site Code.

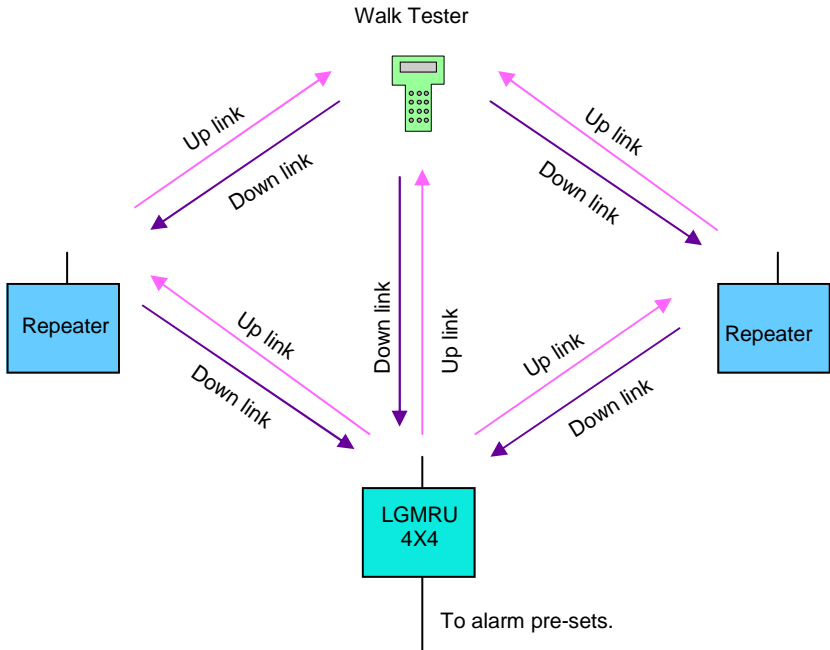

WALK TEST. With switch **12** down the Masthead will be in permanent WALK TEST Mode. In other words, when an alarm event is received it will be re-transmitted back out so that it can be received on a WALK TEST Instrument or PAGER. It is also possible to set the Masthead in WALK TEST Mode by sending a command via RS232 from the control unit or by transmitting a command to it from the WALK TEST Instrument. (See Walk Test Instrument instructions).

NB: Do not leave the system in walk test mode as this uses a lot more air time and could cause a Call In problem on big systems.

RESERVED. Switches 14,15 and 16 are reserved for later features.

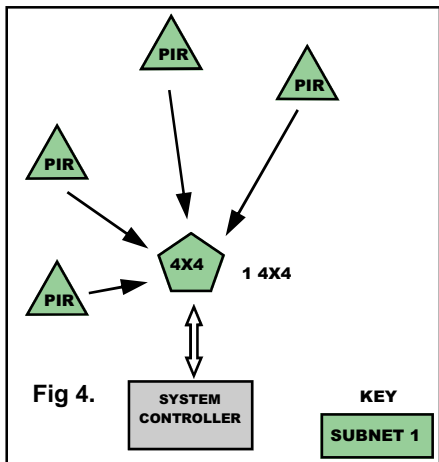
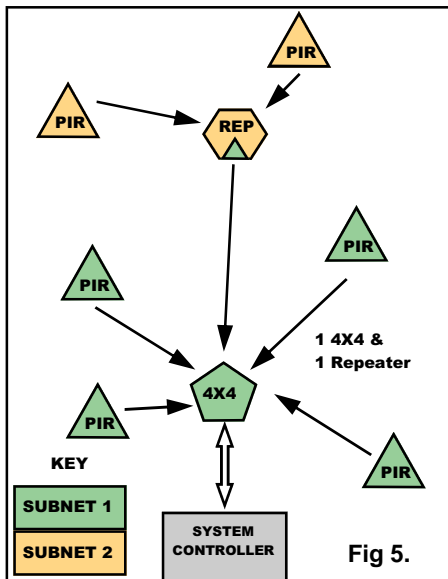
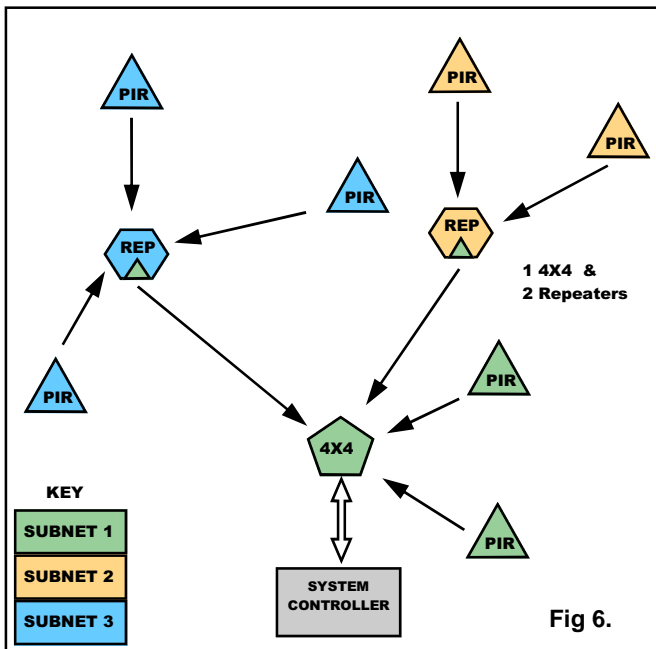

Fig 4 shows PIR's communicating directly with the Masthead. All Sub Nets are 1.



Fig's 5 & 6 show examples where one or more repeaters are used and how the Sub Net Codes separate the system.



SETTING UP AND TESTING THE LGMRU4X4

Step 1. Position the LGMRU4x4 in it's proposed position and fix the supplied antenna. An optional antenna with 5 metres of cable is available (AE434) which will greatly improve radio reception.
Decide on a SITE Code from one of the 32 codes available and set it on the Masthead. Set the SUB NET Codes to 1. Switch unit into Walk Test mode by switching down switch 12.

This example shows Site Code 1
Sub Nets' A & B 1.
Walk Test Mode ON



Step 2. Set the alarm mode switches. The following example is set as alarms 1-8 with 8 alarm outputs without tamper. The contacts are normally closed and the anti-cloak tamper has been disabled.

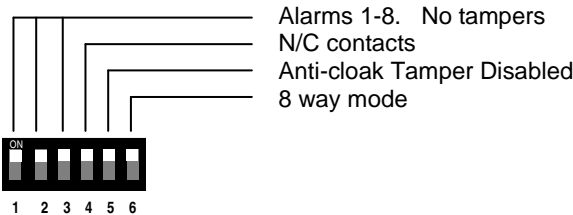

Step 3. Connect the 12 volts DC power supply to the far right terminals 0 & 12V. The alarm contacts are in pairs and numbered 1-4 or 1-8. This depends on switch 6 setting. In the 1-4 mode, each alarm has a corresponding tamper pair. Tamper contacts are always N/C regardless of switch 4 setting which only applies to alarms.

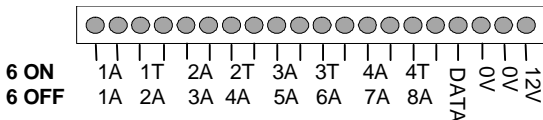

Step 4. Activate the PIR detectors and observe the led indications behind the connection terminals. As these alarms are received the corresponding alarm relay will activate momentarily and the LED indicator will either light or extinguish momentarily depending on whether the alarms are set to N/O or N/C. If a tamper alarm is received then the tamper relay contacts will open and stay open until the tamper is cleared. Shock and Cloak tampers will be cleared next time the PIR calls in an alarm. Open case tampers will only be cleared by closing the case and allowing the PIR to call in an alarm.

STEP 5. While the Masthead Relay Unit is in Walk Test Mode the PIR detectors can be walk tested using the Walk Test Instrument LGWT434. In this mode, the Walk Test Instrument shows the alarm from the PIR detectors via the LGMRU4X4. In this way, the test instrument will show the signal strength at the LGMRU4X4 and proves the entire system.

It is also possible to set the walk test instrument to receive directly from the PIR's if preferred.

STEP 6. Switch off Walk Test Switch 12 and interrupt the power supply to allow the switch change to take effect. Finally, re-fit the lid on the LGMRU4X4.

Engineers Notes.

LOCATION

DATE INSTALLED

SITE CODE

SUB NET A

SUB NET B

UNIT GROUP NUMBER

CONTACTS OPEN OR CLOSED

Types of Receivers

Masthead LGMT434

This transceiver can be used on it's own for a simple pager system or can interface directly with some third party DVR's and alarm systems. It will also connect to the dedicated LGRU64 relay control unit to provide up to 64 relay alarm outputs together with 64 Tamper relay outputs.

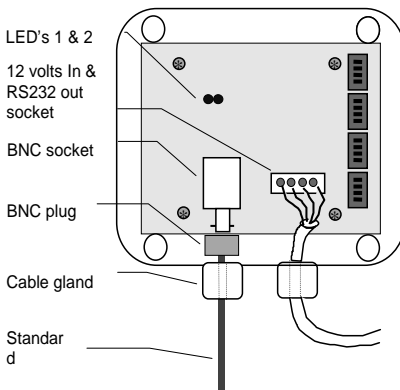

Masthead Relay Unit LGMRU4x4

The masthead relay unit does everything that a masthead unit can do but also provides 4 alarm and tamper relay outputs. This model is primarily intended to connect directly to a dome camera's pre-set inputs but may also be used to connect to DVR's and alarm systems where a smaller number of relay outputs are required. A switch change converts the product to an 8 alarm output without tampers if required. Expansion cards are available to increase the number of alarm outputs up to a maximum of 32.

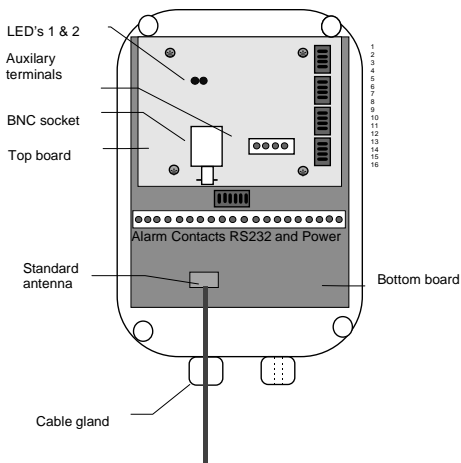

LGMRU4x4 Masthead Receiver Unit Specification.

RF input	434.525Mhz 10m/w
RF output	434.525Mhz 10m/w
Antenna connection	BNC
Antenna	1/4 wave included
RF range	1-2 Km line of sight
Encoding	Manchester with Rolling code
Data out	RS232 and TTL
Alarm contacts	CMOS N/C or N/O
Alarm modes	4 alarms & 4 tampers or 8 alarms only
Operating voltage	12 volts DC
Current consumption	100m/a
Enclosure	ABS L195 W120 H55mm
IP rating	65

Luminite Genesis product range

Wireless PIR's	15m x 90 deg	LGWP1520
Wireless PIR's	40m x 1 deg	LGWP4004
Wireless PIR's	12m Horizontal curtain	LGWP12HC
Masthead/Repeater		LGMT434
Masthead Relay Unit		LGMRU4x4
Relay Expansion Module		LGREM4x4
Walk Test Instrument		LGWT434
16 way relay unit		LGRU16
Relay module		LGRM8
16 way DM interface unit		LGDM16
16 way relay unit with end of line resistor		LGRU16ELR 3 versions
Relay module with end of line resistor		LGRM8ELR 3 versions
Optional antenna		AE434
Transmitter module		LGTX434
Wired PIR detectors (RS485)15m x 90 deg		LGRS1520
Wired PIR detectors (RS485)40m x 1 deg		LGRS4004
Wired PIR detectors (RS485)12m horizontal		LGRS12HC
RS485-RS232 Adapter		LGA485

LUMINITE ELECTRONICS LTD
2a BELLEVUE ROAD, FRIERN BARNET, LONDON, N11 3ER
Tel: 0044 (0) 208 368 7887 Fax: 0044 (0) 208 368 3952
Web: www.luminite.co.uk email: sales@luminite.co.uk