



***LGRS485 Adapter
& LGRS PIR
Detector
Installation
Handbook***

Type: LGA485 & LGRS PIR

Issue 1.

2a BELLEVUE ROAD, FRIERN BARNET, LONDON, N11 3ER
Tel: 0044 (0) 208 368 7887 Fax: 0044 (0) 208 368 3952

PRE-INSTALLATION NOTES

Unpacking.

On receipt, inspect the package and contents for signs of damage. If damage has occurred, advise the carrier and/or suppliers immediately. Inspect the contents to confirm that all items are present and undamaged. If any items are missing or damaged, contact the supplier immediately. It is advisable that the original carton is retained as this forms the safest transport container in the event that a unit has to be returned for any reason.

Servicing.

This unit should not require general servicing. Any repair work should only be undertaken by Luminite Electronics Ltd.

Moisture.

Do not expose the internal electronics of this unit to moisture i.e. take care during installation not to allow rain or damp into the product. When the product is sealed it is water resistant to IP66.

Box Contents.

1 x GENESIS RS485-232 adapter

Copyright 2007 Luminite Electronics Ltd

All rights reserved. Unauthorised duplication of this handbook by any means mechanical or electrical, is strictly prohibited without the express written permission of Luminite Electronics Ltd.

Luminite Electronics Ltd acknowledge all registered trademarks

Luminite Electronics Ltd reserve the right to make changes to this handbook and to its products without prior notice in order to improve design or performance characteristics.

LGA485 & LGRS_PIR Installation Handbook



INDEX

	page
Forward.	2
How the system works.	2 & 3
Wiring diagram.	4
LGRS PIR detector wiring diagram and description	5
LGRS PIR switch settings	6
Relay only or RS485 only.	7
Examples.	10-13



FORWARD.

The Genesis Hard Wired RS485 PIR system provides a simple but reliable and secure means of connecting up to 64 PIR detectors using only a four core cable of up to 300metres. The PIR's are available with the following lenses.

LGRS1520 15 metre x 90 deg. LGRS4004 40 metre x 1 deg and LGRS12HC 12 metre horizontal curtain.

These PIR detectors also have conventional relay contacts which enable them to be connected directly to an alarm input without using the RS485 feature.

The LGA485 adapter has two main functions. Firstly it converts the RS485 communications from the PIR detectors into RS232 which can then be passed to any of the following control units.

LGRU16 LGRU16ELR LGDM16

The second function is to monitor all the PIR's that are connected and report if any fail to communicate. Fig 1 shows a typical example.

NB: The converter will not be required if the PIR's are connected directly to an LGIP64 control unit. (Not shown).

How the system works.

When the power is switched on the adapter first checks the integrity of the load to make sure that it is safe to power up. If the load is correct, power is applied with the correct rise time to enable the detectors and accessories to start correctly. If any of the detectors fail to start, the system will automatically re-start and check again.

Each detector that is connected to the adapter will automatically register with the LGA485 which keeps a record of all devices on line. The detectors will periodically communicate to advise that they are still operative.

Any detector that fails to call in will cause a Missed Call message which activates the corresponding relay on the control unit.

Any alarm or tamper that is sent to the adapter will be converted to the RS232 protocol that is recognised by the above control units.

The typical system in Fig 1 shows a mixture of wired and wireless PIR's working with the Adapter. The RS485 BUS can be up to **300m** and all the detectors are connected in parallel to it. See page 4 for wiring diagram.

The First and Last detector have their switches set accordingly which inform the LGA of how many detectors are connected and allow it to check that they are all operating correctly.

If it is not intended that wireless PIR's are used in the system, it is still recommended that a Masthead be temporarily fitted to facilitate walk testing using the wireless walk test instrument. Once this is completed, the Masthead may be removed.

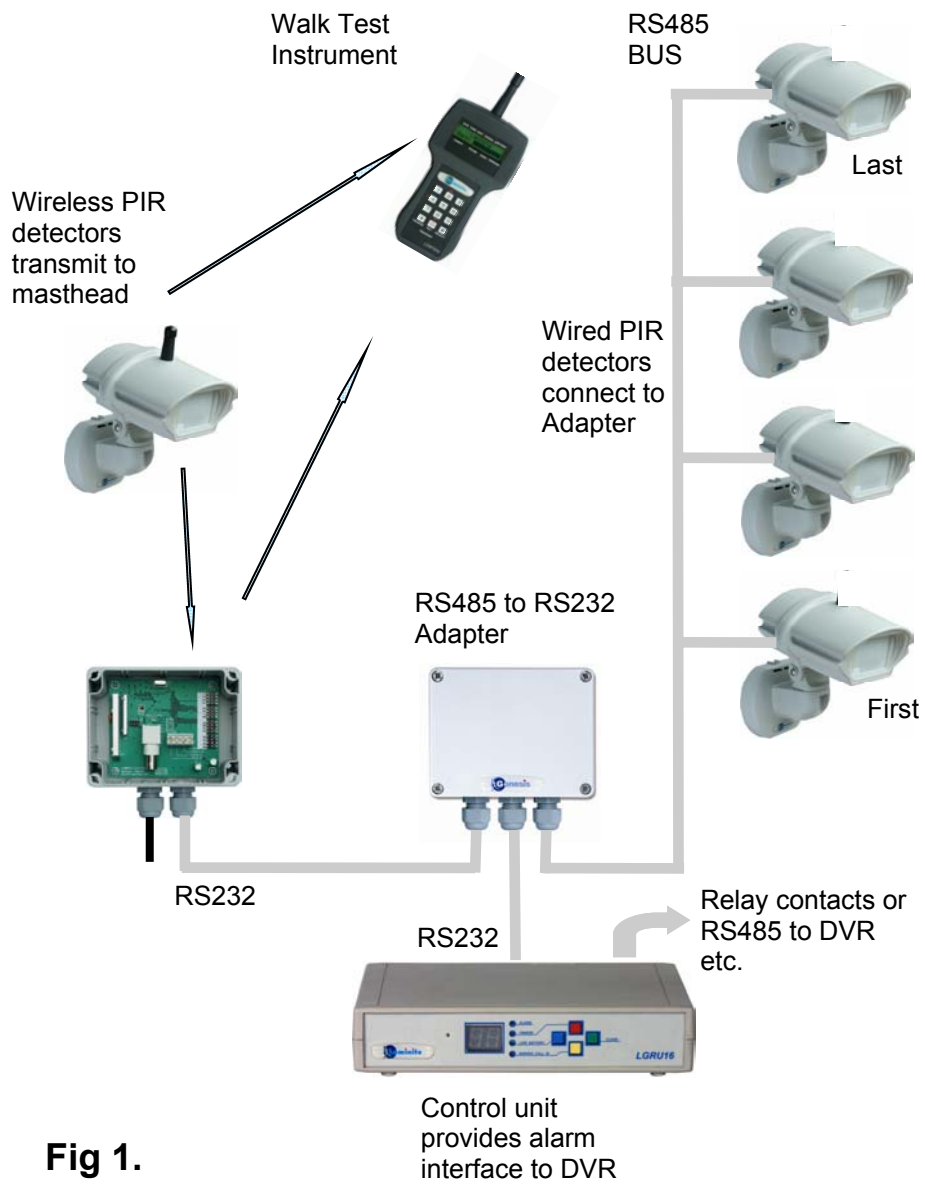

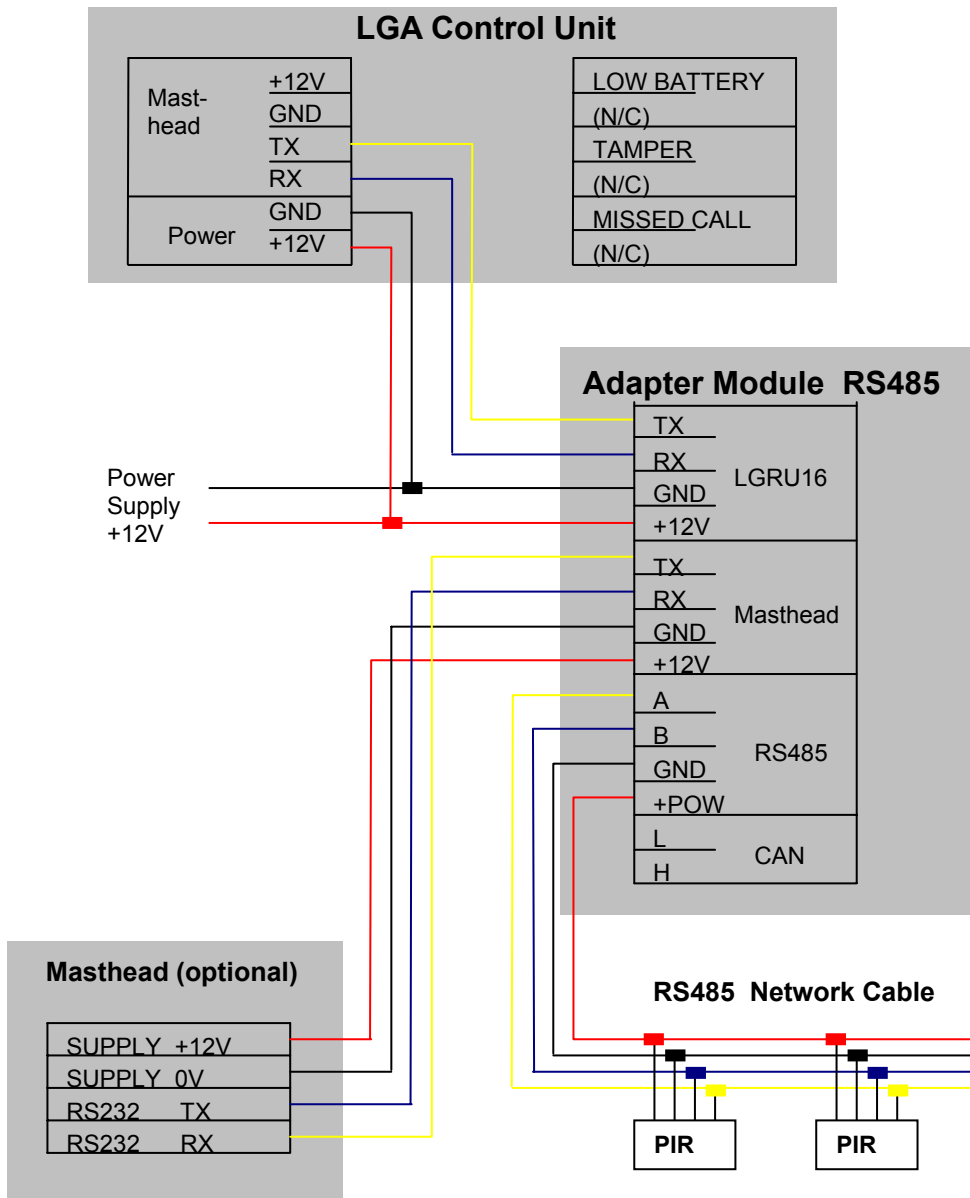

LGRS PIR Detectors

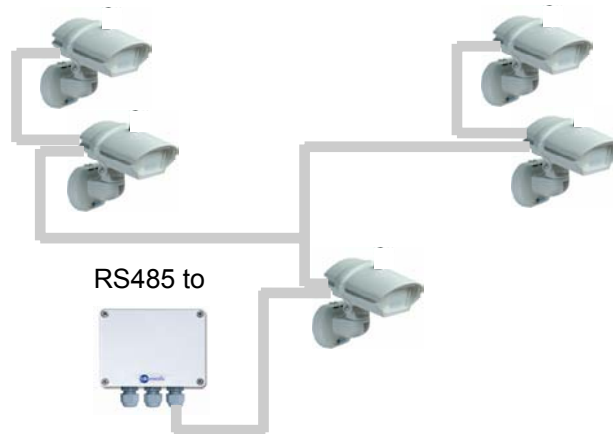

Up to 64 PIR detectors may be connected to one LGA485 adapter using only four core cable which can be up to 300 metres long. The PIR detectors are all connected in parallel as shown in this typical example and may be wired in a daisy chain or back to a central point or perhaps a mixture of both. Each detector must have a unique unit code set which increment from 1 onwards.

The detectors have two cable glands for In and Out connections and screw terminals for the power and RS485 connections. Additional terminals provide volt free relay contacts for conventional alarm and tamper.

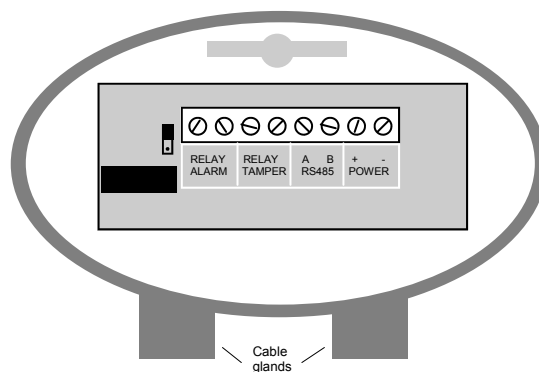

SWITCH SETTINGS

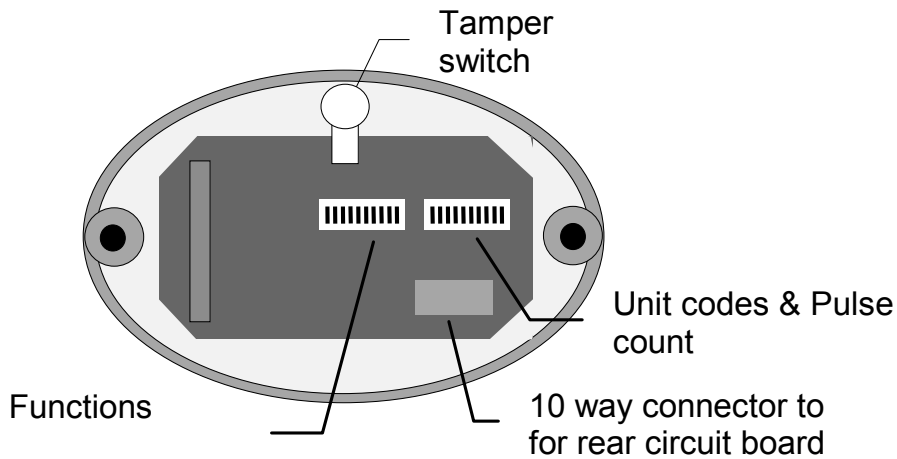

The two banks of switches on the detector board have the following functions

Functions

01 RS485 or Relay Output,	△ = Relay Output, ▼ = RS485 Network
02 ALARM Relay	△ = N/C, ▼ = N/O or
03 TAMPER Relay	△ = N/C, ▼ = N/O or
04 Not used, reserved	
05 Not used, reserved	
06 Not used, reserved	
07 Alarm/Tamper Relay Active Length	
08 Alarm/Tamper Relay Active Length	

Unit codes & pulse count

01 Unit Number
02 Unit Number
03 Unit Number
04 Unit Number
05 Unit Number
06 Unit Number
07 Pulse Sensitivity
08 Pulse Sensitivity

Relay Timeout Selection table

07 | 08 | Relay Timeout

△ △	1s	
△ ▼	2s	
▼ △	5s	
▼ ▼	10s	



Relay operation or RS485 version.

This product can provide either relay outputs only or RS485 but not both. These modes are set using switch no 1.

In the Relay mode, both the alarm and tamper contacts can be changed from N/O to N/C.

Relays only.

In this example the product is set to Relays Only and both the Alarm and Tamper relays are N/C. (Normally closed).



FUNCTIONS

RS485 only.

When set for RS232 output, you must set the switches to indicate First and Last. The example shows that switch 1 is down for RS485 mode and switch 2 down for the first detector and switch 3 down for the last detector. All the in between detectors have switches 2 and 3 up.

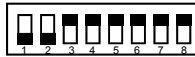

FUNCTIONS

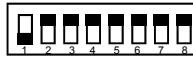

FUNCTIONS

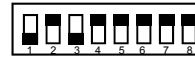

FUNCTIONS



Unit codes.

Start with unit code 1 for the first detector on the system and increase in increments of one for each additional detector. There are 64 unit codes. (1-64)

	SWITCHES	1	2	3	4	5	6
UNIT CODES	1	△	△	△	△	△	△
	2	△	△	△	△	△	▼
	3	△	△	△	△	▼	△
	4	△	△	△	△	▼	▼
	5	△	△	△	▼	△	△
	6	△	△	△	▼	△	▼
	7	△	△	△	▼	▼	△
	8	△	△	△	▼	▼	▼
	9	△	△	▼	△	△	△
	10	△	△	▼	△	△	▼
	11	△	△	▼	△	▼	△
	12	△	△	▼	△	▼	▼
	13	△	△	▼	▼	△	△
	14	△	△	▼	▼	△	▼
	15	△	△	▼	▼	▼	△
	16	△	△	▼	▼	▼	▼
	17	△	▼	△	△	△	△
	18	△	▼	△	△	△	▼
	19	△	▼	△	△	▼	△
	20	△	▼	△	△	▼	▼
	21	△	▼	△	▼	△	△
	22	△	▼	△	▼	△	▼
	23	△	▼	△	▼	▼	△
	24	△	▼	△	▼	▼	▼
	25	△	▼	▼	△	△	△
	26	△	▼	▼	△	△	▼
	27	△	▼	▼	△	▼	△
	28	△	▼	▼	△	▼	▼
	29	△	▼	▼	▼	△	△
	30	△	▼	▼	▼	△	▼
	31	△	▼	▼	▼	▼	△
	32	△	▼	▼	▼	▼	▼
	33	▼	△	△	△	△	△
	34	▼	△	△	△	△	▼
	35	▼	△	△	△	▼	△
	36	▼	△	△	△	▼	▼
	37	▼	△	△	▼	△	△
	38	▼	△	△	▼	△	▼
	39	▼	△	△	▼	▼	△
	40	▼	△	△	▼	▼	▼
	41	▼	△	▼	△	△	△
	42	▼	△	▼	△	△	▼
	43	▼	△	▼	△	▼	△
	44	▼	△	▼	△	▼	▼



Unit codes continued.

	SWITCHES	1	2	3	4	5	6
UNIT CODES							
45		▼	△	▼	▼	△	0
46		▼	△	▼	▼	△	▼
47		▼	△	▼	▼	▼	△
48		▼	△	▼	▼	▼	▼
49		▼	▼	△	△	△	△
50		▼	▼	△	△	△	▼
51		▼	▼	△	△	▼	△
52		▼	▼	△	△	▼	▼
53		▼	▼	△	▼	△	△
54		▼	▼	△	▼	△	▼
55		▼	▼	△	▼	▼	△
56		▼	▼	△	▼	▼	▼
57		▼	▼	▼	△	△	△
58		▼	▼	▼	△	△	▼
59		▼	▼	▼	△	▼	△
60		▼	▼	▼	△	▼	▼
61		▼	▼	▼	▼	‡	△
62		▼	▼	▼	▼	‡	▼
63		▼	▼	▼	▼	▼	△
64		▼	▼	▼	▼	▼	▼

Pulse count.

This sets the sensitivity of the detector. Single pulse is the most sensitive setting and four pulses the least. The normal setting is one but in certain conditions where perhaps there is a lot of wild life, more pulses may be required. See table.

	SWITCHES	7	8	
PULSE COUNT				
1		△	△	UP = △ DOWN = ▼
2		△	▼	
3		▼	△	
4		▼	▼	



FUNCTIONS



Unit code
Unit code
Unit code
Unit code
Unit code
Pulse
Pulse

This example shows a setting of pulse count two.



(example for 4 PIRs in hardwired RS485 network + 4 wireless PIRs):

- 1) Power Supply OFF, make interconnections of all used modules according to previous diagram
- 2) Set DIP switches of all PIRs,

Unit Numbers used for RS485 network must be a seamless group, no matter how many units and what number is first, examples:
- 1,2,3,4,5,6,7,8 or 3,4,5,6 but not 1,2,7,8 !

Example of DIP switches setting for a group of 4 devices in a hardwired RS485 network (Unit Numbers 1,2,3,4):

PIR#1: vv^^^^^^ ^^^^^^^ (mode=RS485net, FIRST, Unit=1, Pulse=1)
PIR#2: v^^^^^^^ ^^^^^v^^ (mode=RS485net, Unit=2, Pulse=1)
PIR#3: v^^^^^^^ ^^^^v^^^ (mode=RS485net, Unit=3, Pulse=1)
PIR#4: v^v^^^^^^ ^^^^vv^^ (mode=RS485net, LAST, Unit=4, Pulse=1)

switch #01 (SUBN2) is OFF (v) for all PIRs in RS485 network,
switch #02 (SUBN1) is OFF (v) only for first PIR (lowest UnitNumber),
switch #03 (SUBN0) is OFF (v) only for last PIR (highest UnitNumber),
switches #04..08 are ON (^) for all PIRs in RS485 network.
(If you want to have only one PIR in RS485 network,
then all 3 switches #01,02,03 must be OFF (v), => FIRST & LAST !)

Unit Numbers used for Wireless network may be any numbers that don't collide with numbers used in RS485 network, examples:
- 9,10,11,12,13 or 9,13,15 (needn't to be seamless).

Example of DIP switches setting for a group of 4 devices in a Wireless network (Unit Numbers 5,6,7,8):

PIR#5: ^^^^^^^^ ^^v^v^^^ (Subnet=1, Site=1, Unit=5, Pulse=1)
PIR#6: ^^^^^^^^ ^^v^v^^^ (Subnet=1, Site=1, Unit=6, Pulse=1)
PIR#7: ^^^^^^^^ ^^v^v^^^ (Subnet=1, Site=1, Unit=7, Pulse=1)
PIR#8: ^^^^^^^^ ^^v^v^^^ (Subnet=1, Site=1, Unit=8, Pulse=1)



- 3) Set DIP switches on LGRU16 PCB,
 - switch #01 OFF (v) = Normal operation (no Debug mode)
 - switches #02,03,04 OFF (vvv) = select group 1..16
 - switch #05 ON (^) if Masthead is used (this enables Masthead detection)
(set #05 OFF (v) if Masthead not used (no wireless PIRs) !)
 - switch #06 ON (^) = LGRU16 will produce Short Messages like „ALARM 03“
(RS232 output 19200Bd from connector Canon9 on LGRU16 PCB)
 - switch #07 ON (^) = enable Alarm Beep
 - switch #08 OFF (v) = Alarm Length 2 sec (or ON = 10 sec)
 - switch #09 ON (^) = add Cloak to Tamper
 - switch #10 ON (^) = add Shock to Tamper
 - switch #11 ON (^) = add Low Battery to Tamper
 - switch #12 ON (^) = add Missed to Tamper
- 4) Power Supply ON
- 5) look at front display of Control Unit LGRU16:
 - If displays „E1“ then no Relay Module GRM8 is detected.
 - If displays „E2“ then no Masthead is detected.
 - In both cases please check interconnection is OK..
 - „E2“ can appear for 2 seconds if Masthead is not used and switch #05 was set OFF (v) => Masthead detection suppressed.
 - If displays „E3“ then press any button on front panel LGRU16.
 - If everything is OK, then 10 sec after Power-Up (Power Supply ON) there is no „Ex“ displayed. There should be „—“.
- 6) Check state of Expansion Module RS485:
 - there are 4 LEDs, named D5,D6,D7,D8 (from edge),
 - wait until first is ON (light) and second is blinking with 1 sec period,
 - it should arise in maximally 3 minutes.
 - If not, then there is some problem with activation of RS485 network power supply => it will not work, check the RS485 cable and connection of particular PIRs, maybe there is some short-circuit..
 - If the second LED is blinking, then RS485 power supply was activated OK.
- 7) Clear the LGRU16 memory:
 - behind front panel of LGRU16 are 2 buttons,



press button LEARN down and hold it for about 10 sec, there is „L „ displayed until „CL“ appears and beeper sounds.
Then release the button, memory has been cleared.

8) Learn all PIRs:

Press button LEARN (and release it), there will be „L „ displayed and alternating with a number of already learned PIRs.

When a new PIR is learned, it makes a long beep and number is incremented. Wait until the number of PIRs reaches expected value and pres LEARN again to stop learning (or let it be, it stops automatically after 20 minutes).

Anytime you can press button LIST to see a list of already learned PIRs.

9) After learning is better to switch OFF the power supply for 10 seconds

10) Switch ON power supply, wait 5 minutes and than all ALARMS should work.

Others recommendations

Cable used for RS485 network should be Category 5, 4 Pair UTP.

This cable contains 4 twisted pairs of wire,

one pair must be used for RS485 signals (Connectors A and B),

one pair (= 2 wires joined altogether) should be +POWER,

and the last two pairs (= 4 wires joined altogether) should be GND.

When the wires are connected (joined) altogether (=in parallel),

then we achieve a lower resistance. It is important, because if we have a long cable, then the resistance of wires can be so high that the voltage decrease (mainly on GND wire) exceeds 7V, and it is a limit for RS485 transceivers used.

With 4 wires joined in parallel we can get 4x longer distance..

Power supply voltage may be +12V only for short distances and small amount of PIRs (to 50m long cable and 4 PIRs).

Power supply on particular PIR must be minimally 8V.

If RS485 network doesn't work properly, please check the voltage between +POWER and GND on the PIR that is the most distant from the expansion module. If the voltage is lower than 8V, then please try to use power supply providing higher voltage (up to 24V may be connected to expansion module).



Some useful facts & computation example

- Power consumption of 1 PIR is about 15 mA
- Resistance of 1 wire of CAT5 cable is about 10 ohm/100m (thats what I measured on my cable..)

Example:

What power supply voltage do we need for network with 10 PIRs, and 300m long cable ?

(lets assume the worst case when all 8 PIRs are connected to the end of cable)

1) compute power consumption of entire network:

$$I = 10 \text{ PIRs} * 15 \text{ mA} = 150 \text{ mA} = 0.15\text{A}$$

2) compute voltage decrease on GND wires (4 wires joined in parallel):

$$\text{resistance} = (10 \text{ ohm} * 3) / 4 = 7.5 \text{ ohm}$$

// *3 because of 300m cable
(=3*100m)

// /4 because of 4 wires in parallel

$$U = R * I = 7.5 * 0.15 = 1.125\text{V}$$

3) compute voltage decrease on +POWER wires (2 wires joined in parallel):

$$\text{resistance} = (10 \text{ ohm} * 3) / 2 = 15 \text{ ohm}$$

// *3 because of 300m cable
(=3*100m)

// /2 because of 2 wires in parallel

$$U = R * I = 15 * 0.15 = 2.25\text{V}$$

4) compute the Power Supply Voltage:

- there must be 8V on PIR power connector
- there is 1.125V voltage decrease on GND wires
- there is 2.25V voltage decrease on +POWER wires
- there is about 1V voltage decrease on expansion module circuits (Current protection circuit and output diode)

$$\text{sum} = 8 + 1.125 + 2.25 + 1 = 12.375 \text{ V}$$

(it is the absolute minimum voltage !)

We recommend to use +3V higher = 15V Power Supply

Luminite Genesis product range

Wireless PIR's	15m x 90 deg	LGWP1520
Wireless PIR's	40m x 1 deg	LGWP4004
Wireless PIR's	12m Horizontal curtain	LGWP12HC
Masthead/Repeater		LGMT434
Masthead Relay Unit		LGMRU4x4
Relay Expansion Module		LGREM4x4
Walk Test Instrument		LGWT434
16 way relay unit		LGRU16
Relay module		LGRM8
16 way DM interface unit		LGDM16
16 way relay unit with end of line resistor		LGRU16ELR 3 versions
Relay module with end of line resistor		LGRM8ELR 3 versions
Optional antenna		AE434
Transmitter module		LGTX434
Wired PIR detectors (RS485)	15m x 90 deg	LGRS1520
Wired PIR detectors (RS485)	40m x 1 deg	LGRS4004
Wired PIR detectors (RS485)	12m horizontal	LGRS12HC
RS485-RS232 Adapter		LGA485

LUMINITE ELECTRONICS LTD
2a BELLEVUE ROAD, FRIERN BARNET, LONDON, N11 3ER
Tel: 0044 (0) 208 368 7887 Fax: 0044 (0) 208 368 3952
Web: www.luminite.co.uk email: sales@luminite.co.uk