

TYPICAL WIRING EXAMPLES FOR GX200 DETECTORS TO DX100 Mk 2 SINGLE ZONE LIGHTING CONTROL UNITS

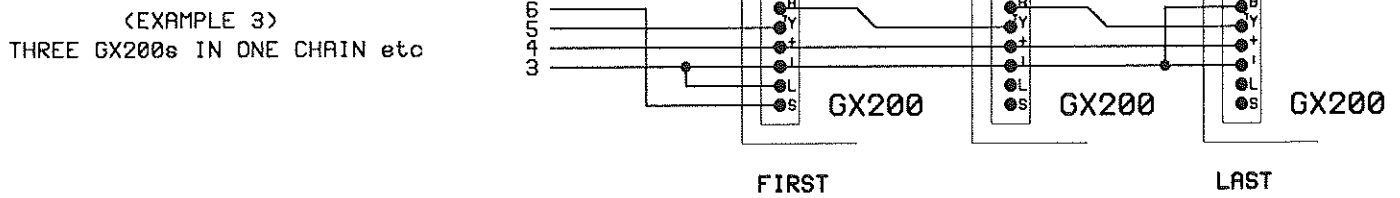
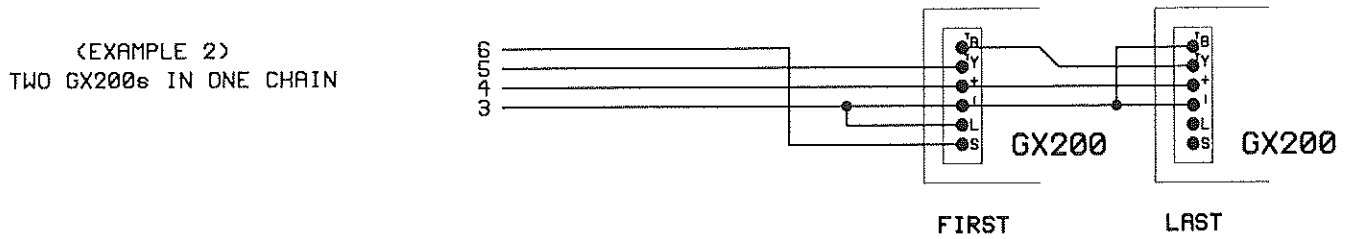
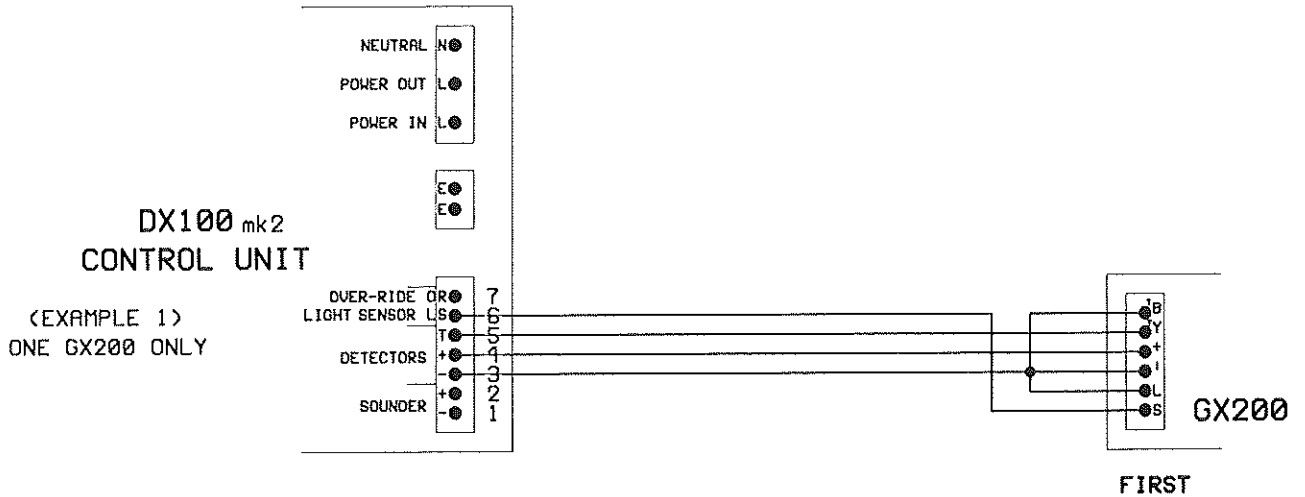

UP TO EIGHT DETECTORS MAY BE WIRED IN THIS WAY

(EXAMPLE 4)
 SIX GX200s IN TWO CHAINS

DX100_{mk2} CONTROL UNIT

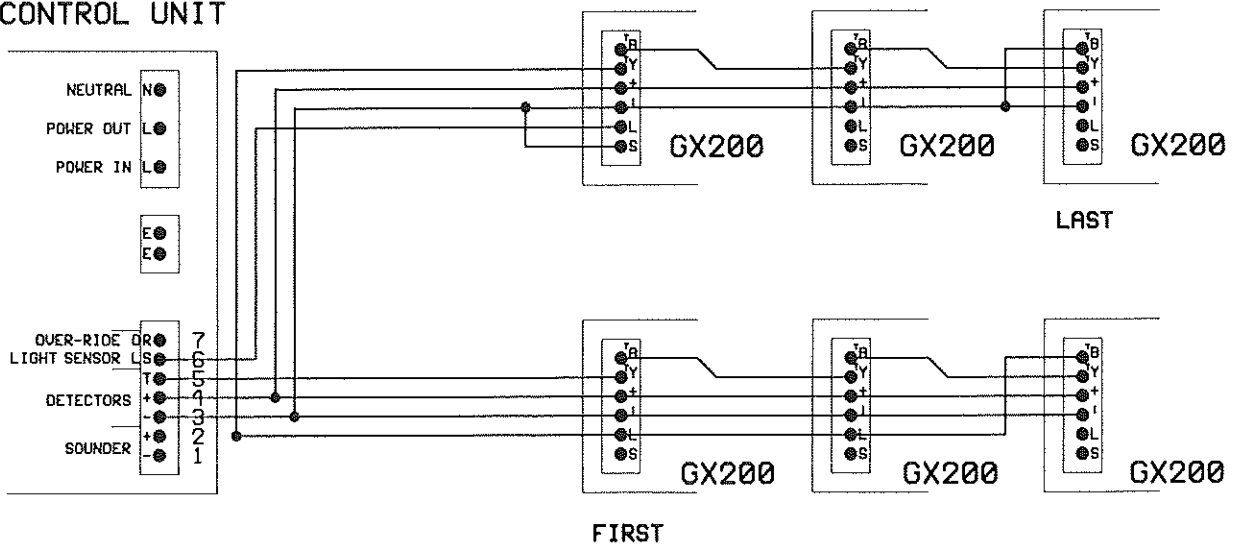

PLEASE NOTE :

FROM THE (FIRST) P.I.R. TO THE NEXT P.I.R.
 THE TERMINALS (L) ARE USED TO LINK FOR EASY WIRING.

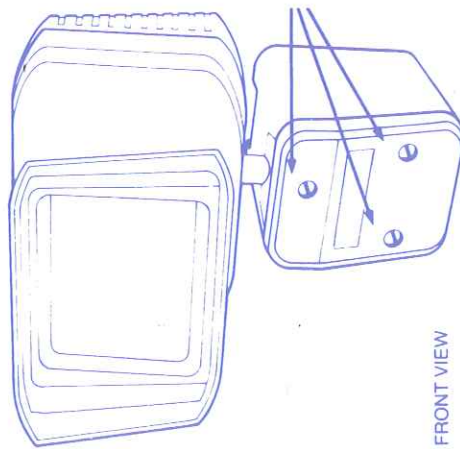

FRONT VIEW

REMOVE 3
SCREWS FOR
ACCESS TO
TERMINALS

FIG.1

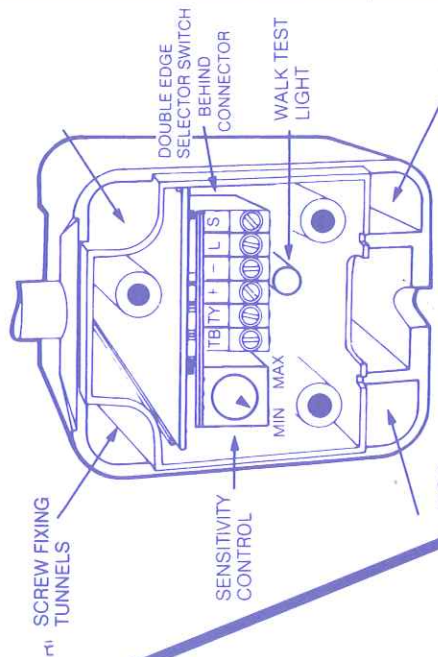

FIG.2

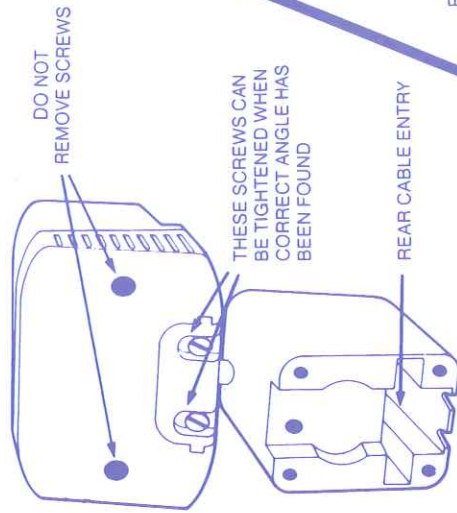

FIG.3

FIG

PLANNING YOUR INSTALLATION

First decide on the location of the detector which should be positioned to cover the required area without over reaching areas such as footpaths and roads. The detector can be angled down to reduce the long range coverage. The detector should be positioned where it can detect people and vehicles crossing in front of it and not walking towards it. Avoid potential false alarm situations (see "AVOIDING FALSE ALARMS").

FIXING TO THE WALL

Remove the front cover (fig. 1) to reveal the connection terminals inside the detector mounting housing. There are four "screw fixing tunnels" on the corners of the detector (fig. 2) into which you should insert No.8 countersunk screws and tighten the detector to the wall.

Use the Drill Template provided.

WIRING INSTRUCTIONS

The detectors may be wired in a chain or alternatively wired back to the control unit using 4 core alarm cable or telephone cable for the first detector and 4 core cable for further detectors (see "WIRING EXAMPLES"). Pass the cable through the rear of the detector before fitting it to the wall (see fig. 3). Choose a suitable circuit from the wiring examples or modify one to suit your own particular requirements. All Digital GX200 Detectors have built-in light sensors. Only one light sensor is used per system as shown in the examples. A single zone (DX100) uses one light sensor and a dual zone (DX102) uses two light sensors. If the Detectors are used with CTV controllers then none of the light sensors are used.

Refer to the "Control Units" wiring instructions for further information. The Detector's six terminals are marked as follows:

- TB & TY Normally closed contacts going momentarily open on detection.
- + & - 12 Volt DC input.
- L & S Light sensor output.

DOUBLE EDGE DETECTION
 The DIGITAL GX200 has optional double edge detection for reducing false alarms. The selector switch is located behind the connector terminals (see fig. 2). When "SINGLE" is selected the detector will be highly sensitive. This is useful for detecting motor vehicles. When "DOUBLE" is selected the detector will still detect genuine alarm situations but will be much less likely to respond to false alarm situations as described under "AVOIDING FALSE ALARMS".

COMMISSIONING
 Switch on the control unit and allow two minutes for the detectors to settle. During this settling period the detectors will activate a number of times. Now observe the red indicator above the connector terminals (fig. 2) which will light each time a movement is detected. Walk about within the detection area and make angle adjustments to the detector until satisfied with the coverage. The red indicator may be hard to see during daylight, however you can use the control unit to advise when movement is detected. Refer to the "Control Units" instructions for further details.

AVOIDING FALSE ALARMS

Careful positioning of the detector will greatly reduce false alarms. Do not let foliage grow around or in front of the detector. Avoid central heating outlets or other heat sources of heat extraction. During daylight, problems can arise with reflective surfaces such as strong sun light reflecting off cars or windows. Having taken these precautions you can further reduce false alarms by decreasing sensitivity or selecting double edge detection.

SENSITIVITY CONTROL

The sensitivity control is located to the left hand side of the connector terminals (as shown in fig. 2). Turn the sensitivity control anti-clockwise to reduce sensitivity. Reduced sensitivity will decrease the detection range.

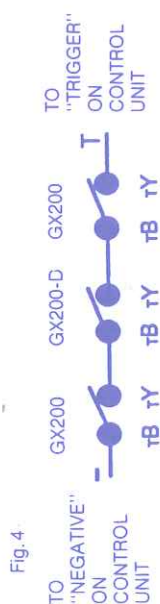

Fig. 4

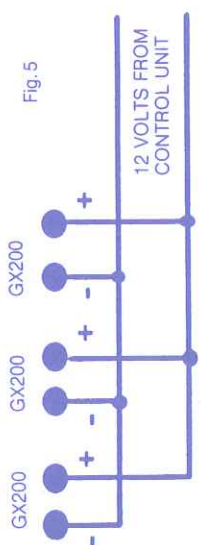

Fig. 5

WIRING PROCEDURE EXPLAINED

The detectors can be thought of as "normally closed" switches which open circuit momentarily when movement is detected. The detectors switch contacts are marked TB & TY. The detectors must be wired in "SERIES" as shown in (fig. 4). One end of the chain is connected to Negative (-) and the other end to the Trigger (T) input on the control unit.

Each detector requires 12 volts DC in order to operate and this is connected to the + and - terminals. The 12 volts must be wired in "PARALLEL" as shown in (fig. 5).

LENS OPTIONS

The Digital GX200 detector is available in three different options:

- 15M STANDARD 15 Metre 90°
- 40M LONG RANGE 40 Metre 1°
- CL CURTAIN 12 Metre 90°

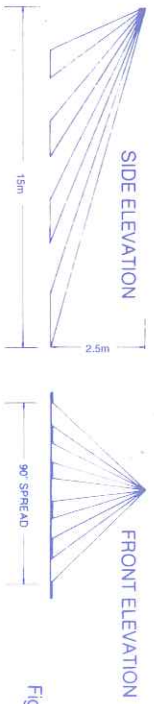

Fig. 6

15 Metre Lens
Mount this detector approximately 2-2.5 metres above the ground for optimum results. The 90° angle makes this lens the most popular choice (see fig. 6). The detector will not respond very quickly if you walk straight towards it. Always position the detector so that you walk across it's field of view.

40 Metre Lens
Mount this detector approximately 2-2.5 metres above the ground for optimum results. The 1° angle of detection gives a spread of about 4 metres at it's furthest range. Careful adjustment is required with this model as a tiny angle or tilt adjustment will result in a large change in the viewing area 40 metres away (see fig. 7).

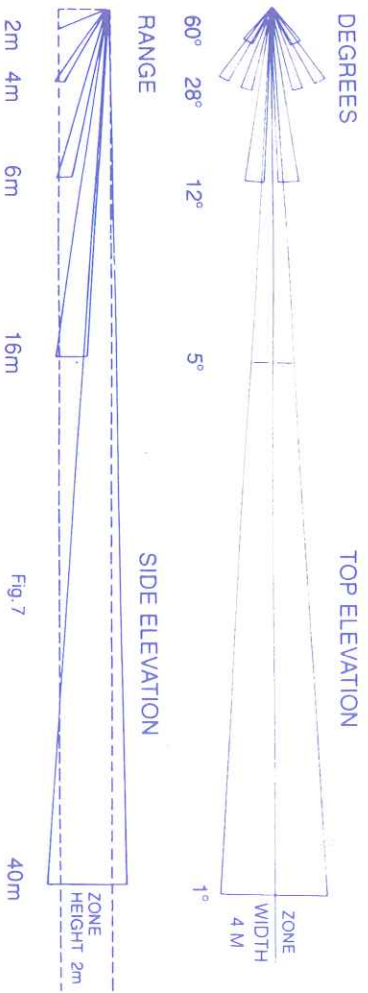

Fig. 7

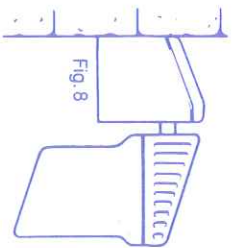

Fig. 8

Curtain Lens
The curtain lens model can be mounted either vertically or horizontally as shown.

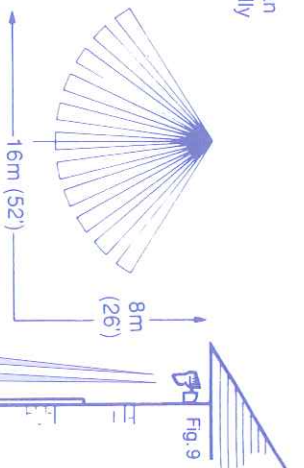

Fig. 9

Curtain Lens
IMPORTANT: When fitting the detector in a VERTICAL position the head should be rotated 180° as shown in (fig. 8). This allows the water to run off the sloping top of the detector.

Vertical mounted "Curtain Lens" detector
For covering across a flat wall of a building, mount the detector as shown in (fig. 9) so that it looks straight down giving coverage across windows and doors but not looking out further than 1 metre. This lens is ideal for alleys and side ways or for short front gardens.

Horizontal mounted "Curtain Lens" detector
This lens does not have any *creep zones* therefore if the detector is fitted about 2 metres above the ground it will detect in a similar way to the standard lens detector but will not view the ground area. This can be useful if there are animals wandering as the detector will not be able to see them. The detector will not respond very quickly if you walk straight towards it. Always position the detector so that you walk across it's field of view (fig. 10).

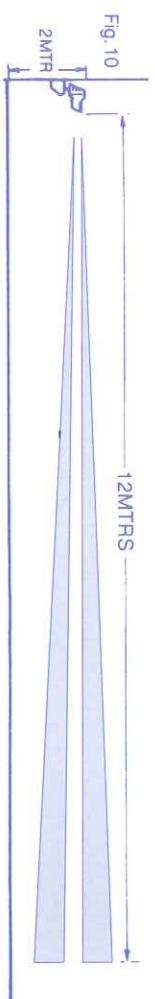

Fig. 10

